

Wide range of copy templates.

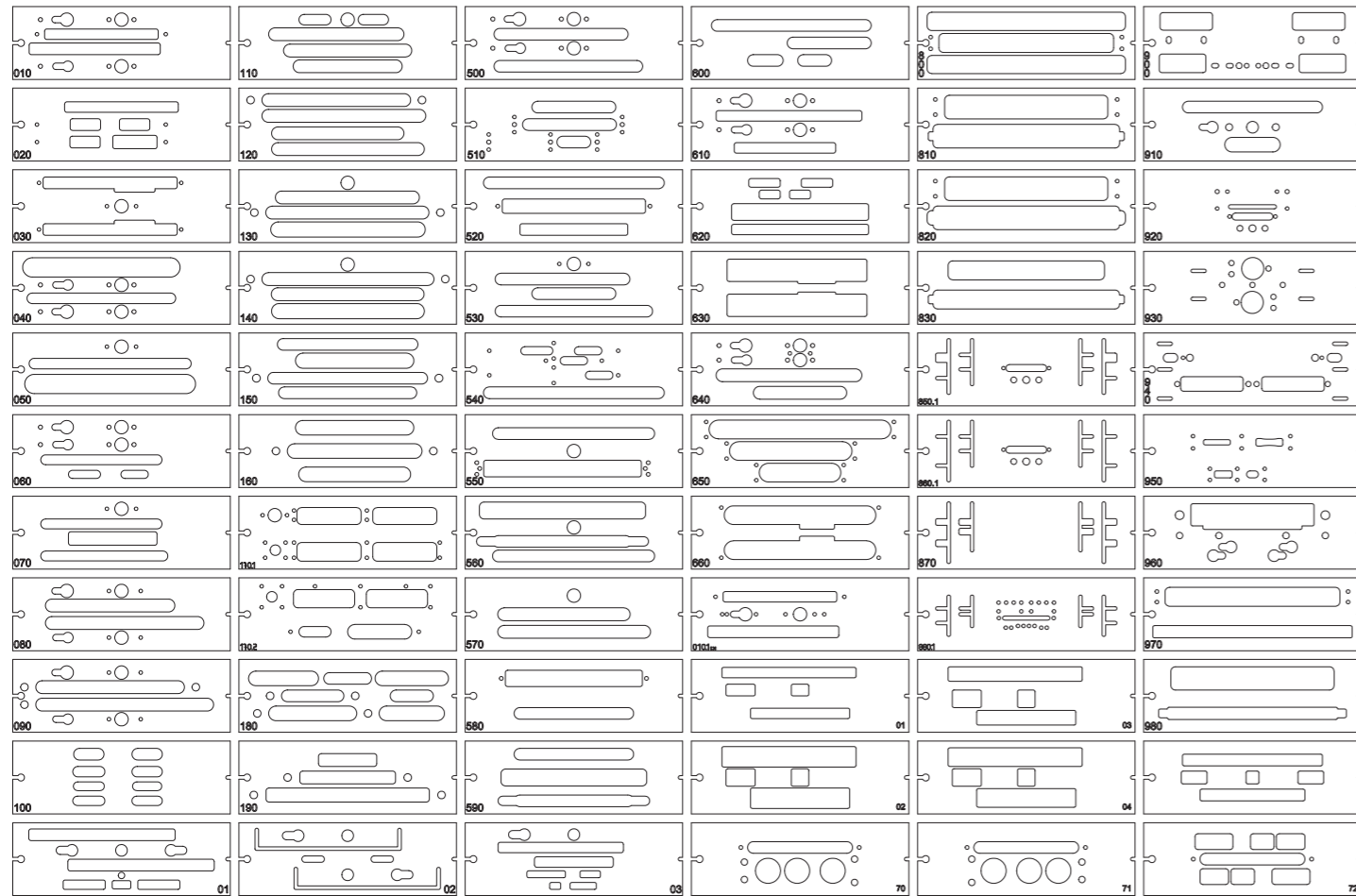

**CE**

2.000rpm  
4.000rpm

110  
140  
340

1,1kW

Collet CM2

3+T+N  
400Volt

6÷8Bar

160 kg

1.200  
900  
2.650\*

The Company reserves the right to amend and improve its products without notice.

## Copy router for steel reinforcement profiles of pvc doors

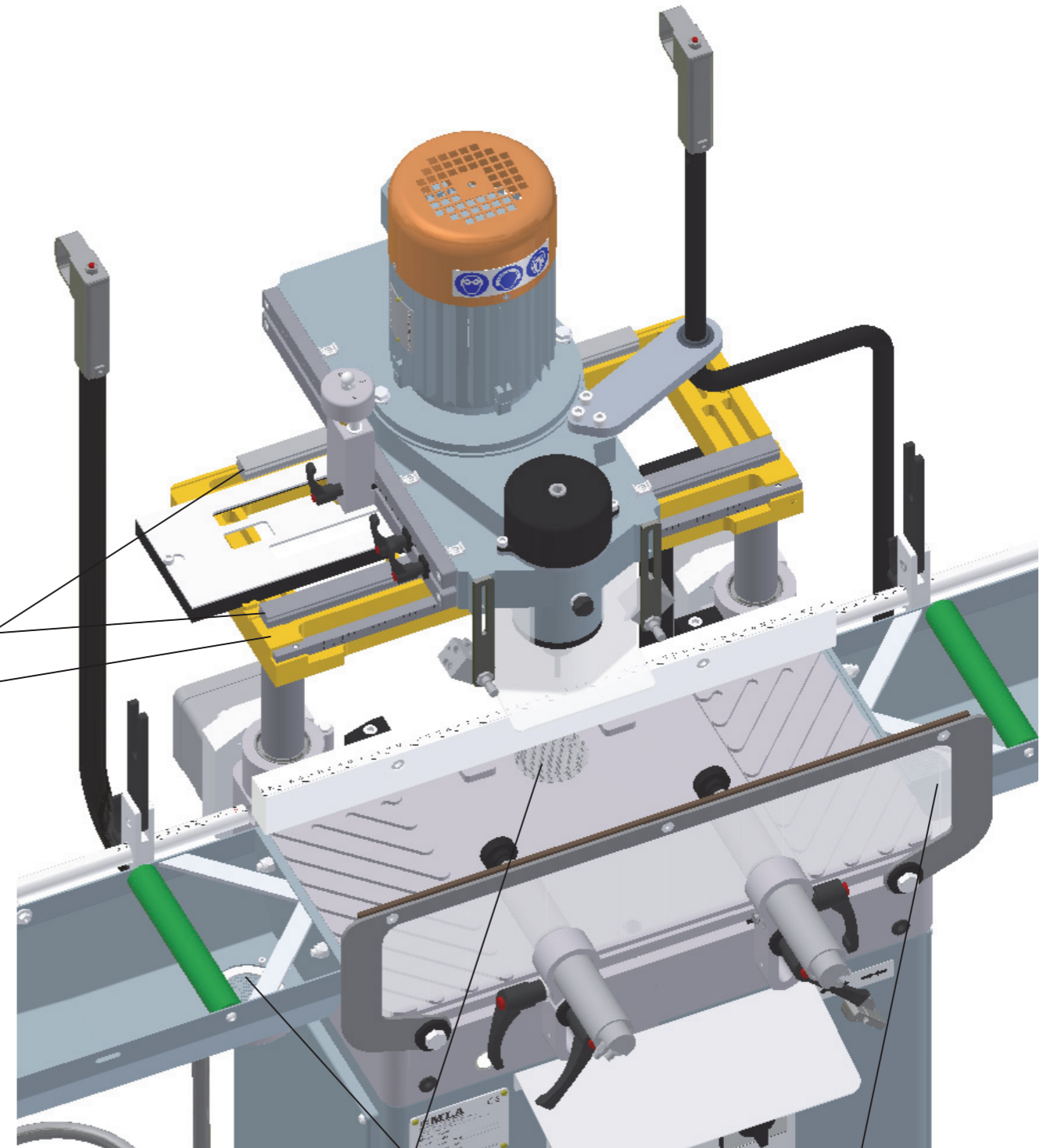

Linear rail guides (A, axis x and y) are fixed on a strong cast iron support (B), which enables the operator to work in a very stable way and without vibrations.

Coolant recovery openings filter the liquid and convey it back to the tank.

Plastic strips avoid the coolant dripping on the outside: the liquid is conveyed back onto the working table and then into the coolant recovery system.

Vertical descent stop button: only the right lever must be moved while milling.

Push button of the 2-diameter pneumatic copy pin (5-6).

Functioning:

- 1) The profile is clamped at low pressure;
- 2) By pushing simultaneously the pneumatic buttons placed on the handles of the right and left levers, the high pressure clamping is activated and the mist sprayers and vertical motor are set in motion. The motor is equipped with a thermic feeler that stops the feeding in case of overheating, protecting the integrity of the motor itself.

Double mist sprayer to work steel.

Special lever to reduce the effort.

6+6 foldaway stops on the lateral supports in 3 available lengths: 1m/2m/2,5m.

4 vertical descent stops on the revolver.

